



Received: July 16, 2024  
Revised: August 12, 2024  
Accepted: August 15, 2024

\*Corresponding author: Nur Annisa Lutaan Dongi, Department of Economics and Development Studies, Faculty of Economics and Business, Universitas Tadulako, Central of Sulawesi, Indonesia.

E-mail: [nnisalutaandongi@gmail.com](mailto:nnisalutaandongi@gmail.com)

## DESCRIPTIVE OF QUANTITATIVE DATA | SUPPLEMENTARY

# The Role of BAPPEDA In Formulating Planning and Budgeting in Intervening in Poverty Reduction

Nur Annisa Lutaan Dongi<sup>1</sup>, Yunus Sading<sup>2</sup>, Eko Jokolelono<sup>3</sup>, Andi Herman Jaya<sup>4</sup>, Farida Milias Tuty<sup>5</sup>

<sup>1,2,3,4,5</sup> Department of Economics and Development Study, Faculty of Economic and Business, Universitas Tadulako, Central of Sulawesi, Indonesia. Email: [nnisalutaandongi@gmail.com](mailto:nnisalutaandongi@gmail.com)<sup>1</sup>, [yunussading.iesp@gmail.com](mailto:yunussading.iesp@gmail.com)<sup>2</sup>, [jokolelono.eko@yahoo.com](mailto:jokolelono.eko@yahoo.com)<sup>3</sup>, [andihermano6@gmail.com](mailto:andihermano6@gmail.com)<sup>4</sup>, [faridamilias\\_tuty@yahoo.com](mailto:faridamilias_tuty@yahoo.com)<sup>5</sup>

**Abstract:** Various poverty reduction programs, especially in Central Sulawesi, have been implemented by the government, including in the socio-economic, health and education sectors. Mapping the poverty reduction program plan is needed to increase the effectiveness of each program implemented. The poverty reduction programs launched by the government have not been able to significantly reduce the poverty rate. In order to reduce poverty, it is necessary to take strategic, comprehensive and sustainable steps that can have an impact on reducing poverty. The purpose of this study is to see how the role of Bappeda in formulating planning and budgeting to reduce poverty in Central Sulawesi. The method used in this research is a descriptive qualitative method. The results of this study indicate that bappeda as a facilitator and the process of formulating planning and budgeting has carried out its duties as regulated by law. The Central Sulawesi BAPPEDA in formulating poverty reduction planning compiles the Annual Regional Development Plan in the form of the Regional Government Work Plan (RKPD) through the implementation of absorption and aspiration gathering in the form of a Development Planning Consultation (Musrenbang) forum. The results of the Musrenbang contain a budget framework for activity plans that need to be funded by funding sources, be it the Regency APBD, Provincial APBD, APBN or other sources of funds. After the musrenbang, the RKPD is determined, which is then contained in the PERDA.

**Keywords:** Bappeda, Planning, Budgeting, Poverty.

## 1. INTRODUCTION

The issue of poverty in a global context has become an international agenda item. At the end of September 2015, leaders from 193 member countries of the United Nations gathered at the UN headquarters to discuss worldwide poverty issues. Consequently, the 2030 Agenda, a historic agreement on transformative, comprehensive, and long-term universal goals and targets, was adopted. To achieve sustainable development, the Sustainable Development Goals (SDGs) aim to eradicate poverty in all its forms, including extreme poverty (Khalil and Aras, 2018). National development is a series of sustainable development efforts encompassing all aspects of community and state life to improve the standard of living and welfare of the Indonesian people, thereby achieving the national goals outlined in the 1945 Constitution. To achieve optimal development outcomes, each step in the development process must be carried out systematically. Development planning involves the systematic preparation of all activities related to development. The objectives of development are determined based on needs and limitations. In addition to planning, the budgeting of regional development is equally important. Construction planning and development budgeting are interconnected and significantly impact the implementation of the development process.

According to data from the Central Statistics Agency (BPS) as of March 2023, the poverty rate in Central Sulawesi reached 12.41%, representing approximately 389,710 people. This figure shows an increase compared to 12.30% in September 2022 and 12.33% in March 2022. The detailed development of the number of poor people in Central Sulawesi can be seen in the following chart:





Figure 1. Poverty Rate (percentage)

Source: BPS, data processed by SEPDAK Bappenas

The chart above indicates that the poverty rate in Central Sulawesi has relatively increased from 2021 to 2023. The government has implemented several poverty alleviation programs, particularly in Central Sulawesi, focusing on social, economic, health, and education issues. Mapping out a plan for poverty alleviation programs is crucial for enhancing the effectiveness of these initiatives. Despite these efforts, the government's poverty alleviation programs have not significantly reduced poverty levels. To address poverty, strategic, comprehensive, and long-term measures are necessary. The Regional Development Planning Agency (BAPPEDA) plays a vital role in preparing development plans and assisting regional governors within the administrative area of Central Sulawesi in formulating policies and implementing poverty alleviation programs. Therefore, studying aspects related to poverty in each region is crucial. Based on data from the Central Statistics Agency over the past two years, the absolute number of poor people has increased. Given this, the author has chosen the title "Analysis of the Role of BAPPEDA in Formulating Planning and Budgeting to Intervene in Poverty Reduction in Central Sulawesi Province."

## 2. LITERATURE REVIEW

### 2.1 Development Planning

According to Law No. 25 of 2004, Article 1, planning is the process of considering available resources and determining appropriate future actions through a series of options. Regional development planning is viewed as a plan to enhance the utilization of public resources in the region and strengthen the capacity of the tourism sector to responsibly generate value from private resources. In this context, regional development planning is seen as an integrated economic unit involving various interconnected factors.

### 2.2 Budgeting

Budgeting is the process of creating a financial plan for an organization. This involves preparing a work plan for a specified period, typically one year, and expressing it in monetary terms. Budgeting is an integral part of an organization's planning, which usually includes strategic planning, plan development, and budget formulation (Mahsun, 2019). Proper allocation of budgets according to regional capabilities and development plans reflects the local government's commitment to achieving the community's welfare.

### 2.3 The Concept of Planning and Budgeting

Ensuring consistency between planning and budgeting is crucial as it serves as a tool for evaluating the performance of local governments. This consistency guarantees that all government programs and activities are effectively executed to achieve the predetermined objectives. It significantly impacts the realization of the vision, mission, goals, targets, and policies outlined in planning documents and plays a vital role in implementing development initiatives aimed at improving public welfare. These initiatives focus on enhancing human resource competencies and fostering economic growth (Bunna, 2022).



## 2.4 Poverty

Poverty is an urgent national issue that requires a systematic, integrated, and comprehensive approach to address. It is generally defined as a condition characterized by insufficient financial resources and assets necessary for survival. Poverty is marked by the inability to meet essential needs, including food, shelter, clothing, education, and healthcare. In general terms, poverty is understood as a condition where income is inadequate to meet basic needs, thereby failing to ensure a sustainable livelihood (Suryawati, 2004). The World Bank, in its publication "Attacking Poverty," defines poverty as a state of not reaching a satisfactory standard of living. The World Bank uses criteria such as inadequate provision of clothing, food, and shelter; limited access to healthcare services; and low educational attainment to determine a person's poverty status (Adji, 2020). Briefly, poverty represents a low standard of living, where there is a lack of material resources among certain individuals or groups compared to the general living standards in the surrounding community.

## 2.5 Previous Research

Attaullah (2023) found that despite the tsunami and COVID-19 disasters, local government efforts in Palu have been effective in poverty alleviation. However, factors such as insufficient budget allocation and lack of community recognition of government initiatives hinder the performance of local government agencies in addressing poverty in Palu. Auliyani and Muhammad (2022) reported that development in Mandailing Natal Regency is in accordance with the planning by BAPPEDA of Mandailing Natal Regency, but it has not been fully implemented. Rasbin (2018) noted a decline in unemployment and poverty rates in Yogyakarta and Malang. This decrease is closely linked to regional initiatives aimed at poverty alleviation and unemployment reduction. In Yogyakarta, initiatives include the Family Report Card program, the Segoro Amarto Movement, KUBE, and corporate social responsibility (CSR) efforts by various companies. Malang City's government has incorporated poverty and unemployment reduction strategies into its mission as outlined in the 2013–2018 RPJMD. The role beyond Malang City's budget is fulfilled by various businesses and banks. Ajizah et al. (2021) highlighted the significant role of BAPPEDA Kota Depok in the formulation of regional development plans for Depok City. This role is crucial in governmental activities related to planning, research, and development. During the preparation of the 2016–2021 RPJMD, BAPPEDA Kota Depok faced various challenges, including inaccuracies in data or information and a lack of skilled personnel at BAPPEDA.

## 3. RESEARCH DESIGN AND METHOD

The type of research used in this study is qualitative. The qualitative research method, based on post-positivist philosophy, is employed to investigate the natural conditions of the object. A qualitative descriptive approach is used to analyze the role of BAPPEDA in formulating budgets for poverty alleviation. This approach explains how BAPPEDA formulates plans to tackle poverty by reviewing the existing literature. This method provides insights into existing data and offers examples for research studies to develop clear discussions on the issues under investigation.

## 4. RESULT AND DISCUSSION

According to the Central Statistics Agency (BPS) and Minister of Home Affairs Regulation No. 86 of 2017, the percentage of the poor population is calculated by comparing the number of poor people to the total population in a specific area at a particular time. This calculation is based on regional performance indicators. Over the past decade, the poverty rate in Central Sulawesi has generally decreased but remains higher than the national poverty rate. Below is the data on the poverty rate development in Central Sulawesi Province:





Figure 2. Poverty Rate

Source: BPS, Data Processed by SEPAKAT Application

In 2021, the poverty rate in Central Sulawesi Province was 13.00%, indicating a slight increase of 0.08% from 2020. The region's poverty rate in 2021 was still higher than the national average. As an area with a relatively balanced urban and rural population, Central Sulawesi's poverty rate was lower than the national rural poverty rate but higher than the national urban poverty rate.

#### 4.1. Research Findings

##### *Formulation Process of Poverty Reduction Planning*

The development plan formulation process is conducted through the Musrenbang, a forum for development planning discussions starting from the district level to the city or regency level. Musrenbang serves as a public consultation platform where stakeholders discuss strategic issues faced by the community. It involves preparing the Regional Government Work Plan (RKPD), which includes gathering and absorbing public aspirations. The stages in the RKPD preparation process are guided by laws and regulations, such as Law No. 25 of 2004 and Minister of Home Affairs Regulation No. 54 of 2010. The initial step involves reviewing the work plans of each regional apparatus organization (SKPD), which accommodates community interests and needs. Once the Regional Medium-Term Development Plan (RPJMD) is established, it becomes the basis for the RKPD. The stages are as follows:

1. Preparing the initial draft of the RKPD, which includes agenda-setting, data collection, and information gathering.
2. Developing the initial RKPD draft, which outlines strategic issues, policies, and work targets for each priority area, based on public input and discussions with the Regional House of Representatives (DPRD).
3. Drafting the RKPD, which involves integrating SKPD work plans into the initial RKPD draft and refining it into the final RKPD.
4. Conducting Musrenbang for the RKPD, where BAPPEDA gathers inputs from the community to finalize the RKPD. This process identifies priority programs for the region's development.
5. Finalizing the RKPD draft, incorporating feedback from the Musrenbang discussions.
6. Issuing a Governor's regulation to formally establish the RKPD, which then guides regional budget preparation.

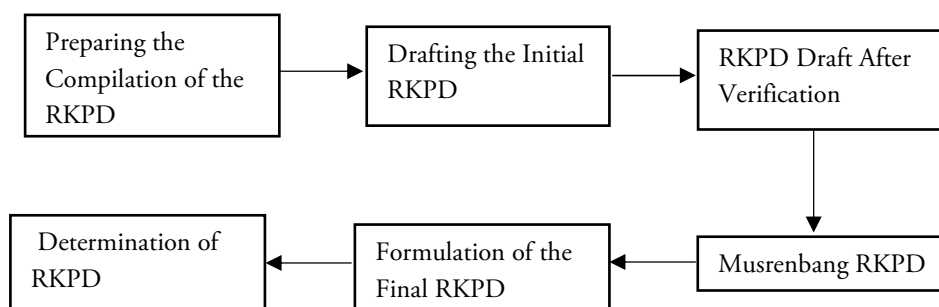

Figure 3. Sequence of the RKPD Formulation Process

The preparation of the RKPD involves various stakeholders, including the community and academics, focusing on poverty alleviation in Central Sulawesi Province. Several programs specifically aimed at reducing poverty are outlined in the RKPD, with details provided in the following table:

Table 1. List of Programs and Budget Allocations

OPD	Program	Budget Year	
		2022	2023
Education and Culture	Management of High School Education	244.807.899.975	3.869.000.000
	Management of Vocational Education	253.850.041.050	3.000.000.000
	Management of Special Education	21.457.524.763	1.996.225.575
Health	Personal and Public Health Efforts	55.633.889.400	40.408.615.475
Social	Social Rehabilitation	4.149.450.702	1.789.706.000
	Social Security Protection	13.639.544.950	12.959.230.000
	Basic Social Rehabilitation for Homeless and Beggars		205.000.000
Public Works and Water Resources	Management and Development of Water Supply Systems	13.920.782.475	7.700.000.000
	Management and Development of Drainage Systems		5.155.000.000
	Management and Development of Wastewater Systems	560.888.100	2.500.000.000
	Water Resources Management	57.930.834.736	2.406.788.570
	Settlement Development		13.650.000.000
Maritime Affairs and Fisheries	Management of Capture Fisheries	1.241.750.000	11.900.000.000
	Management of Aquaculture	2.136.861.464	
Cooperatives and SMEs	Business Licensing for Savings and Loans	14.999.850	110.400.000
	Health Assessment of Cooperatives	240.708.650	192.146.150
	Empowerment and Protection of Cooperatives	487.884.975	437.132.300
	SME Empowerment	334.645.900	724.067.000
	SME Development	633.810.800	688.591.150
	Cooperative Training and Education	1.119.545.625	160.000.000
	Cooperative Training and Education	139.999.800	135.000.000
	Supervision and Inspection of Cooperatives	138.987.625	206.832.350
Energy and Mineral Resources	Promoting SME Growth	1.297.018.500	604.328.000
	Geological Aspects Management	2.433.224.100	1.623.289.643
	Renewable Energy Management	3.899.194.000	135.000.000
	Electricity Management	1.320.000.000	160.000.000
Population	Population Registration	349.999.575	512.120.000
	Civil Registration	349.999.625	512.120.000
	Population Profile Management	199.999.825	59.100.000

OPD	Program	Budget Year	
		2022	2023
Women's Empowerment and Child Protection	Gender Mainstreaming and Women's Empowerment	195.768.800	275.000.000
	Quality Family Improvement	2.526.248.808	5.705.000.000
	Gender and Child Data Management	55.123.050	1.250.000.000
Population Control and Family Planning	Population Control		40.000.000
	Community and Family Welfare Empowerment	593.701.075	399.988.650
	Family Planning (KB) Development	642.223.875	122.130.000
PMD	Inter-Village Cooperation Enhancement	100.000.225	78.381.700
	Community and Customary Law Institution Empowerment	100.000.025	233.887.915
Library and Archives	Library Development	892.158.850	76.145.700
Industry and Trade	Industry Planning and Development	247.984.900	402.910.300
	Stabilization of Basic Goods Prices	270.602.500	910.787.500
Food	Management of Economic Resources for Food Sovereignty and Independence	13.576.959.336	9.600.000.000
	Handling Food Insecurity	2.421.470.482	1.300.000.000
	Enhancing Diversification and Community Food Security	14.044.654.170	16.502.430.000
Agriculture and Plantation	Provision and Development of Agricultural Facilities	40.712.089.755	38.885.771.472
	Provision and Development of Agricultural Infrastructure	33.740.920.275	24.596.306.228
	Agricultural Business Licensing	513.920.800	300.000.000
	Agricultural Extension	7.888.422.904	7.060.000.000
	Agricultural Disaster Control and Mitigation	813.317.000	906.160.000
Public Works	Road Management	73.014.628.778	589.300.000.000
Manpower and Transmigration	Development of Transmigration Areas	452.721.299	4.877.545.000
	Construction of Transmigration Areas	2.857.535.723	185.000.000
	Employment Placement	1.345.879.595	
Tourism	Development of Tourism and Creative Economy Resources		179.758.450
	Enhancing Tourism Destination Attractions		61.333.000
Settlement	Settlement Development	20.321.860.713	2.541.700.000
Youth Affairs	Youth Competitiveness Capacity Development	73.154.500	127.985.000
Plantation and Livestock	Provision and Development of Agricultural Facilities	1.234.779.000	561.000.000
	Provision and Development of Agricultural Infrastructure	693.010.000	7.602.500.000
	Agricultural Extension		91.320.000
Forestry	Forest Management	139.999.925	

Source: Poverty Reduction Analysis in Central Sulawesi 2022-2023 (processed data)

Several programs have shown positive results in reducing poverty rates in Central Sulawesi Province. These include social security protection programs, such as the Family Hope Program (PKH) and direct cash assistance (BLT). Other notable programs include the management of electricity supply, health insurance programs, and infrastructure improvement projects, such as road construction. BAPPEDA acts as a facilitator in policy formulation and tracks the activities of 22 regional government agencies (OPDs) to ensure that each has a budget for their programs. After the budgeting process, these OPDs are invited by the social and cultural affairs department of BAPPEDA



to review their poverty alleviation budgets. BAPPEDA monitors and evaluates the details of activities and budgets from these OPDs. It was noted that the tourism department did not have a budget for poverty alleviation programs in 2022, and similarly, the forestry department had no such budget in 2023, despite having regional budget (APBD) funds.

#### *Budgeting Process for Poverty Reduction Programs*

Government Regulation No. 58 of 2005 on Regional Financial Management serves as a guideline for regional financial management. According to Article 55, the Regional Financial Management Official (PPKD) is required to notify all regional apparatus no later than three days after the regional budget draft (RAPBD) is set. This notification allows the regional apparatus to prepare and submit their Draft Budget Implementation Document (DPA-PD) within six days of receiving the PPKD's notice. BAPPEDA plays a crucial role as a facilitator in the planning and budgeting processes, which are then incorporated into the regional budget (APBD). As a facilitator, BAPPEDA coordinates with the Regional House of Representatives (DPRD) on various programs and activities. Once these are approved by the DPRD, a Regional Regulation (PERDA) is established, which includes budget allocations for these programs and activities, including those aimed at poverty alleviation. In preparing the budget, BAPPEDA collaborates with the financial department of the provincial secretariat to discuss development plans that are subsequently ratified as a PERDA. The following diagram provides an overview of this process:

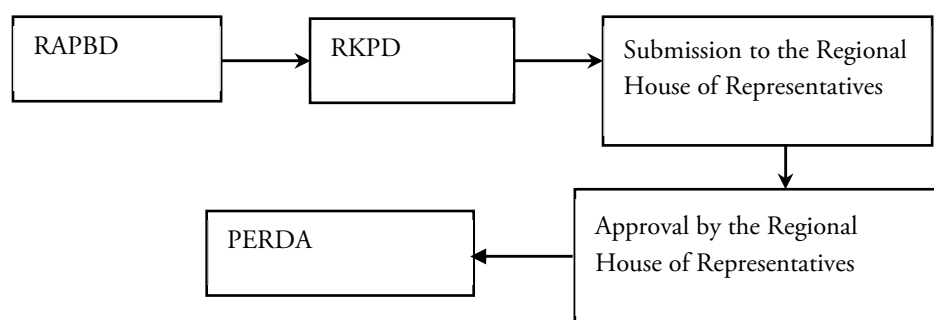

**Figure 4. Budgeting Formulation Process**

From the figure 4, it is evident that there is a strong interconnection between planning and budgeting. The regional regulation encompasses a variety of priority programs or activities aimed at regional development, one of which includes programs or policies for poverty alleviation.

#### *4.2. Research Findings*

##### *The Role of BAPPEDA in Formulating Poverty Alleviation Plans*

In the implementation of regional development, the role of stakeholders—including local governments, communities, and the private sector—is crucial. The preparation of the Regional Poverty Alleviation Plan (RKPD) serves as a replacement for the Regional Poverty Alleviation Strategy (SPKD). This aims to build cross-sectoral commitment and synergy among stakeholders in addressing regional poverty. The RKPD is developed through the Musrenbang process, starting from the village, district, regency, and provincial levels, up to the national level. This process involves stakeholders, including the community and academics, allowing the government to absorb public aspirations. The RKPD document guides regional apparatus in drafting their work plans, which subsequently serve as the basis for budgeting documents. To accelerate poverty eradication in Central Sulawesi, BAPPEDA Central Sulawesi has implemented innovations related to poverty reduction, such as Gercep, Gaskan, and Berdaya, focusing on community empowerment. These initiatives aim to:

1. Improve coordination, monitoring, and evaluation of poverty alleviation efforts.
2. Facilitate the provision of basic needs assistance for people with disabilities through social welfare support.
3. Facilitate social welfare assistance for families.
4. Coordinate, monitor, control, and evaluate poverty alleviation efforts at the city/regency level, and promote the growth of MSMEs to enhance job creation, income distribution, economic growth, and poverty reduction.

#### *The Role of BAPPEDA in Budgeting for Poverty Alleviation*

BAPPEDA serves as a facilitator in the planning and budgeting processes, which are incorporated into the regional revenue and expenditure budget (APBD). BAPPEDA's role includes initiating the determination of budget ceilings and coordinating with the Regional House of Representatives (DPRD) on proposed programs. Once approved by the DPRD, these programs are formalized into a Regional Regulation (PERDA), which includes allocated funds for poverty alleviation initiatives. The allocated budget for poverty alleviation is detailed as follows:

**Table 2. Poverty Alleviation Budget**

Year	Allocation Budget	Poverty (%)
2022	901,758,622,828	12,33
2023	827.972.733.128	12,41

Source: RAT Poverty Data for 2022 – 2023

As a facilitator in the budgeting and coordination of the regional revenue and expenditure budget, BAPPEDA allocated Rp. 901,758,622,828 for poverty alleviation in 2022, with the poverty rate at 12.33%. In 2023, the allocation was Rp. 827,972,733,128, with a poverty rate of 12.41%. Although there was a budget increase from 2022 to 2023, the effectiveness of budget policies in accelerating poverty alleviation in Central Sulawesi has been questioned, as the poverty rate increased in 2023. Several factors contributed to the increase in poverty from September 2022 to March 2023, including:

1. The Farmer's Exchange Rate (NTP) in March 2023 was 101.83, an increase of 2.84 points from September 2022's NTP of 98.99.
2. The economy contracted by 0.79% in the first quarter of 2023 compared to the third quarter of 2022.
3. The distribution progress of social assistance for the staple food program in the first quarter of 2023 was 88.2%, while the Family Hope Program (PKH) was 92.4%.
4. The open unemployment rate (TPT) in February 2023 was 3.49%, an increase of 0.49 points from 3.00% in August 2022.

## 5. CONCLUSIONS

Addressing poverty alleviation is not an easy task and presents numerous challenges. BAPPEDA and the relevant OPDs must efficiently utilize available budgets to implement integrated programs and activities that effectively target the intended outcomes. As a facilitator in the formulation and budgeting process for development planning, BAPPEDA plays a crucial role in reducing poverty rates. In Central Sulawesi, BAPPEDA formulates poverty alleviation plans by preparing the Annual Regional Development Plan, structured as the Regional Government Work Plan (RKPD). This process involves absorbing and collecting public aspirations through the Musyawarah Perencanaan Pembangunan (Musrenbang) forum. The results of the Musrenbang outline the budget framework for activities to be funded by sources such as the regional budget (APBD), provincial budget, national budget (APBN), and other funding sources. Once the Musrenbang is concluded, the RKPD is formalized and included in the Regional Regulation (PERDA). The Musrenbang's role in the RKPD



formulation process includes determining the budget framework for activities, where BAPPEDA considers priority programs to reduce poverty in Central Sulawesi. BAPPEDA should enhance coordination among local governments in formulating policies and poverty alleviation programs. This is crucial to ensure that the planning and programs proposed by BAPPEDA are well-integrated within the context of regional development policies and visions. Additionally, it is important to conduct regular evaluations of the implemented programs to assess their success and impact.

## REFERENCES

- Ajizah, Nur, Siti, Wijaya, Endra, Meutia, & Febri. (2021). Peran Badan Perencanaan Pembangunan Daerah (Bappeda) Kota Depok Dalam Penyusunan Rencana Pembangunan Jangka Menengah Daerah (The Role of Local Development Planning Agency (Bappeda) of Depok City in Planning the Midterm Local Development Programs). *Jurnal Legal Reasoning*, 4(1), 44–64.
- Ardi Adji, Hidayat, T., Tuhiman, H., Kurniawati, S., & Maulana, A. (2020). Pengukuran Garis Kemiskinan di Indonesia: Tinjauan Teoretis dan Usulan Perbaikan. 1–36. [www.tnp2k.go.id](http://www.tnp2k.go.id)
- Attaullah, M. I. (2023). Kinerja Badan Perencanaan Pembangunan Daerah Dalam Pengentasan Kemiskinan di Kota Palu Provinsi Sulawesi Tengah. 282.
- Auliyani, M., & Muhammad, Y. (2022). Peran Badan Perencanaan Pembangunan Daerah ( BAPPEDA ) Dalam Perencanaan Pembangunan ( Studi Kasus Pembangunan Di Daerah Kabupaten Mandailing Natal ). *Jurnal Cendekia Ilmiah*, 1(2), 94–105.
- Bunna, O. T. (2022). Pengaruh Perencanaan Dan Kompetensi Sumber Daya Manusia Terhadap Penyerapan Anggaran Yang Dimoderasi Oleh Komitmen Organisasi Pada Pemerintahan Kabupaten Toraja Utara The.
- Khalil, S., & Aras, M. (2018). Pemetaan indikator sustainable development goals (SDGs) yang berpotensi sebagai indikator rencana jangka menengah kabupaten Indragiri Hilir 2019 - 2023. *Selodang Mayang*, 4(2), 81–90. <https://ojs.selodangmayang.com/index.php/bappeda/article/view/95>
- Mahsun, M. (2019). Konsep Dasar Penganggaran. *Penganggaran Sektor Publik*, 256. <http://www.pustaka.ut.ac.id/lib/ekap4403-penganggaran-sektor-publik/#tab-id-3>
- Rasbin. (2018). Peran Pemerintah Daerah dalam Mengurangi Tingkat Kemiskinan dan Penganggaran. *Jurnal DPR*, 23(2), 129–142. <http://www.jurnal.dpr.go.id>
- RAT kemiskinan sulawesi tengah 2022-2023. (2023).
- Sugiyono. (2014). *Metodologi Penelitian Kuantitatif, Kualitatif dan R & D*.

